

B780



Product Features:

- Fixed power size 2/3 EN compliance
- Adjustable closing & latching speed
- Maximum door opening angle at 110 °
- Mechanical hold-open at 90 ° (optional upon request)

Power size	2	3
Max. Door width (mm)	900	1000
Max. Door weight (kg)	100	

Accessories:

- Standard arm
- Pivot
- Offset arm

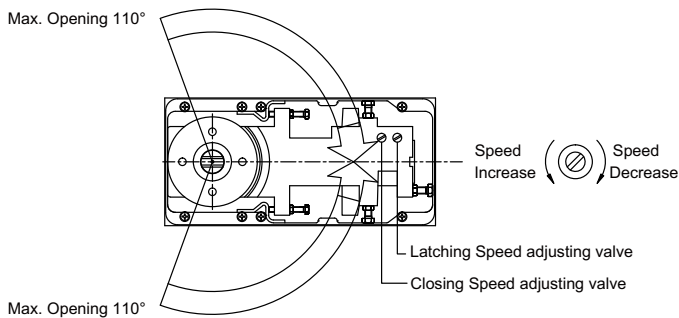

Dimensions:

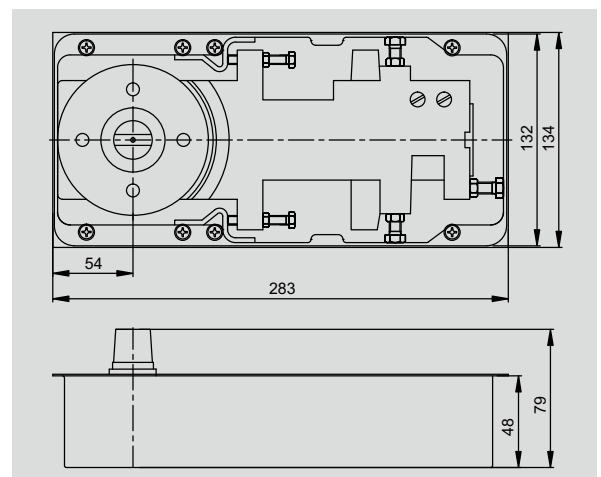

Application Ranges:

- Suitable for single & double action door
- Available for light & medium duty

Length (mm) : 10
 Width (mm) : 10
 Height (mm) : NA

Finishes:

- Painted – gold & other colors upon request & discussion